



- Compact design
- Au-clad contacts that can even use low level circuit and little chattering and bouncing
- Easy wiring with full-open terminals
- Mounting are possible to both front and back
- Type with a lamp is available
- Dust-proof, waterproof, oil resistant construction (IP64)
- Zinc coated* type available (bolts and nuts)

*roller arm type

PRODUCT TYPE

1. Standard type

| Actuator | Part No. |
|-----------------------|----------|
| Push plunger | AZ8111 |
| Roller plunger | AZ8112 |
| Cross roller plunger | AZ8122 |
| Roller arm | AZ8104 |
| Adjustable roller arm | AZ8108 |
| Adjustable rod | AZ8107 |
| Flexible rod | AZ8166 |
| Spring wire | AZ8169 |

Note) When ordering an overseas-specified product, refer to the Overseas Standards given below.

FOREIGN STANDARDS

| Standard | Applicable product | Part No. |
|----------|---------------------------------------------------------------------------------------|------------------------------------------------------------------------------------------------------|
| UL | File No. : E122222 Ratings : 5A 250V AC Pilot duty B300 | Order by standard part No. However, add "9" to the end of the part No. for the model with neon lamp. |
| | Product type : Standard model, with neon lamp | |
| CSA | File No. : LR55880 Ratings : 5A 250V AC Pilot duty B300 | Order by standard part No. |
| | Product type : Standard model, with neon lamp | |
| TÜV | File No. : J9551203 Ratings : AC-15 2A/250V~ Product type : Standard model only | Order by standard part No. |

2. With neon lamp

| Lamp connection | Actuator | Lamp rating | Part No. |
|-----------------|-----------------------|----------------|----------|
| Spring type | Push plunger | 100 to 200V AC | AZ811106 |
| | Roller plunger | | AZ811206 |
| | Cross roller plunger | | AZ812206 |
| | Roller arm | | AZ810406 |
| | Adjustable roller arm | | AZ810806 |
| | Adjustable rod | | AZ810706 |
| | Flexible rod | | AZ816606 |
| | Spring wire | | AZ816906 |

Note) When ordering an overseas-specified product, refer to the Overseas Standards given below.

3. With LED

| Lamp connection | Actuator | Lamp rating | |
|-----------------|-----------------------------|-------------|--------------|
| | | 12V DC | 24 to 48V DC |
| | | Part No. | |
| Spring type | Push plunger | AZ8111161 | AZ811116 |
| | Roller plunger | AZ8112161 | AZ811216 |
| | Cross roller plunger | AZ8122161 | AZ812216 |
| | Roller arm | AZ8104161 | AZ810416 |
| | Adjustable roller arm | AZ8108161 | AZ810816 |
| | Adjustable rod | AZ8107161 | AZ810716 |
| | Flexible rod | AZ8166161 | AZ816616 |
| | Spring wire | AZ8169161 | AZ816916 |
| | Remote wire control plunger | AZ8181161 | AZ818116 |
| Lead wire type | Push plunger | AZ8111661 | AZ811166 |
| | Roller plunger | AZ8122661 | AZ811266 |
| | Cross roller plunger | AZ8122661 | AZ812266 |
| | Roller arm | AZ8104661 | AZ810466 |
| | Adjustable roller arm | AZ8108661 | AZ810866 |
| | Adjustable rod | AZ8107661 | AZ810766 |
| | Flexible rod | AZ8166661 | AZ816666 |
| | Spring wire | AZ8169661 | AZ816966 |

Notes 1. LED rating 6V DC type is available. When ordering, add suffix 162(spring type) or 662(lead wire type) to the standard part No.
2. The DC24-48V rated lamp is recommended for PC input use.

4. Option

| | Application | Part No. |
|--------------------------|------------------------|----------|
| VL limit conduit adapter | VL, VL with lamp, VL-T | AZ8801 |

5. Protective construction

| Protective construction | VL mini limit SW | VL mini limit SW (with indicator) |
|-------------------------|------------------|-----------------------------------|
| IEC | | |
| IP60 | ○ | ○ |
| IP64 | ○ | ○ |

6. Lamp rating

| Types | Rated operating voltage | Operating voltage range | Internal resistor |
|-----------|-------------------------|-------------------------|-------------------|
| Neon lamp | 100 to 200V AC | 80 to 240V AC | 120kΩ |
| LED | 6V DC | 5 to 15V DC | 2.4kΩ |
| | 12V DC | 9 to 28V DC | 4.7kΩ |
| | 24 to 48V DC | 20 to 55V DC | 15kΩ |

SPECIFICATIONS

1. Rating

1) Standard type

| Rated control voltage | Load | Resistive load (cos φ ≃ 1) | Inductive load (cos φ ≃ 0.4) |
|-----------------------|------|----------------------------|------------------------------|
| 125V AC | | 5A | 3A |
| 250V AC | | 5A | 2A |
| 125V DC | | 0.4A | 0.1A |

2) Type with indicator

| Types | Rated control voltage | Resistive load (cos φ ≃ 1) | Inductive load (cos φ ≃ 0.4) |
|----------------|-----------------------|----------------------------|------------------------------|
| With neon lamp | 125V AC | 5A | 3A |
| | 240V AC | 5A | 2A |
| With LED | 24V DC | 3A | – |

2. Characteristics

| | | | |
|--------------------------------------------|---------------------------------------------------------------------------------------------------------------------------------------------------------------------------|--------------------------------------------------------------------------------------------------------|--|
| Contact arrangement | 1 Form Z | | |
| Initial contact resistance, max. | 15mΩ (By voltage drop 6 to 8V DC at rated current) | | |
| Contact material | Gold clad over silver | | |
| Initial insulation resistance (At 500V DC) | Min. 100MΩ | | |
| Initial breakdown voltage | 1,000Vrms for 1 min Between non-consecutive terminals 2,000Vrms for 1 min Between dead metal parts and each terminal 2,000Vrms for 1 min Between ground and each terminal | | |
| Shock resistance max. | In the free position | Max. 98m/s ² {10G} | |
| | In the full operating position | Max. 294m/s ² {30G} | |
| Vibration resistance | Standard type: Max. 55Hz Type with indicator: 10 to 50Hz, double amplitude of 1.5mm | | |
| Expected life (Min. operations) | Mechanical | 10 ⁷ (at 120 cpm) | |
| | Electrical | 3×10 ⁵ (at rated resistive load) 5×10 ⁶ (Magnetic contactor FC-100 200V AC load) | |
| | Life of lamp | Min. 2×10 ⁴ hours (Neon lamp type) | |
| Ambient temperature/Ambient humidity | –20 to +60°C –4 to +140°F/Max. 95% | | |
| Max. operating speed | 120 cpm | | |

3. EN60947-5-1 performance

| Item | Rating |
|----------------------------------------|----------|
| Rated insulation voltage (Ui) | 250VAC |
| Rated impulse withstand voltage (Uimp) | 2.5kV |
| Switching overvoltage | 2.5kV |
| Rated enclosed thermal current (Ithe) | 5A |
| Conditional short-circuit current | 100A |
| Short-circuit protection device | 10A fuse |
| Protective construction | IP64 |
| Pollution degree | 3 |

4. Operating characteristics

| Characteristics | O.F. (N {gf}) max. | R.F. (N {gf}) min. | Pretravel (P.T.), max. mm inch | Movement Differential (M.D.), max. mm inch | Overtravel (O.T.), min. mm inch | Totaltravel (T.T.), min. mm inch |
|-----------------------------|--------------------------------------------------------------------------------------------------------------------------------------------------------------------------|----------------------------------------------------------------------------------------------------------|--------------------------------------------------------------------------------|------------------------------------------------------------|--------------------------------------|----------------------------------|
| Actuator | | | | | | |
| Push plunger | 8.83 {900} | 1.47 {150} | 1.5 .059 | 0.7 .028 | 4 .028 | 5.5 .217 |
| Roller plunger | | | | | | |
| Cross roller plunger | | | | | | |
| Roller arm | 5.88 {600} | 0.49 {50} | 20° | 10° | 75° | 95° |
| Adjustable roller arm | 7.84 {800}~3.35 {342} | 0.49 {50}~0.21 {21} | 20° | 10° | 75° | 95° |
| Adjustable rod | 7.84 {800}~1.99 {203} | 0.49 {50}~0.12 {12} | 20° | 10° | 75° | 95° |
| Flexible spring wire | 0.88 {90} | – | 30 (1.181) | – | 20 (.787) | 50 (1.969) |
| Remote wire control plunger | 19.61 {2,000}~24.52 {2,500}* 19.61 {2,000}~24.52 {2,500}* 1.96 {200}~1.96 {200}* 1.5 .059 4 .157* 0.7 .028 2.0 .079* 4.5 .177 2.0 .079* 6 .236 6 .236* | 1.96 {200}~1.96 {200}* 1.5 .059 4 .157* 0.7 .028 2.0 .079* 4.5 .177 2.0 .079* 6 .236 6 .236* | 1.5 .059 4 .157* 0.7 .028 2.0 .079* 4.5 .177 2.0 .079* 6 .236 6 .236* | 0.7 .028 2.0 .079* 4.5 .177 2.0 .079* 6 .236 6 .236* | 4.5 .177 2.0 .079* 6 .236 6 .236* | 6 .236 6 .236* |

*Characteristics measured at bent condition: min. radius 100mm 3.937inch.

Notes 1. Keep the total travel values in the specified range. Otherwise the actuator force may rise to several times the operating force, resulting in a mechanical failure or much shorter service life.
2. For the operating characteristics, refer to the TECHNICAL INFORMATION.

DATA

1. Life curve

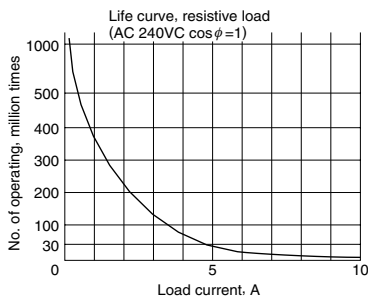

2. Actual load life curve (relay coil load)

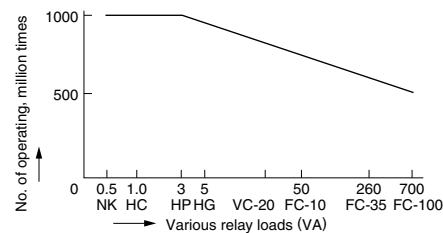

Note: The FC magnetic contactor series is 200V AC. The K is 2 Form C 24V DC type.

WIRING DIAGRAM

Output circuit

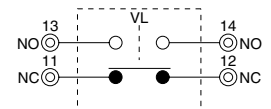

Terminal

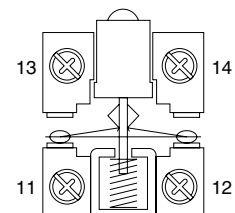

General tolerance: $\pm 0.4 \pm .016$

DIMENSIONS

Push plunger type

Standard type
AZ8111CEJ

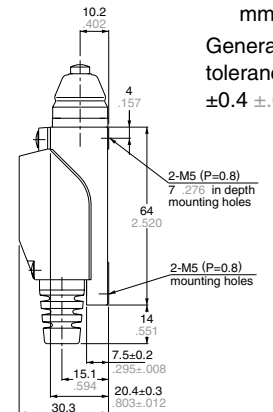
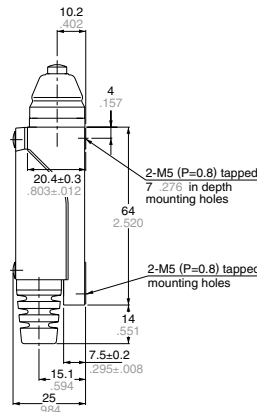
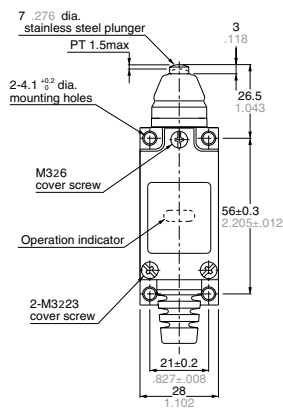

(Standard type)

(With Neon lamp)

Roller plunger type

Standard type
AZ8112CEJ

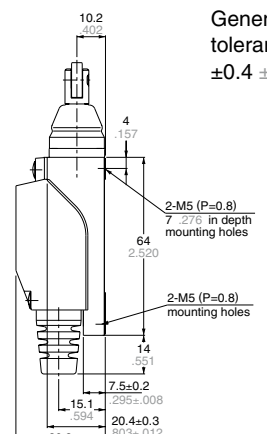
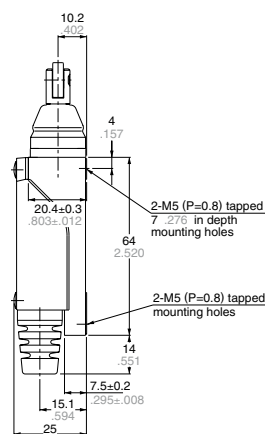
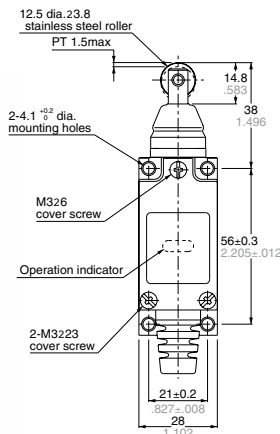

(Standard type)

(With Neon lamp)

General tolerance: $\pm 0.4 \pm .016$

Cross roller plunger type

Standard type
AZ8122CEJ

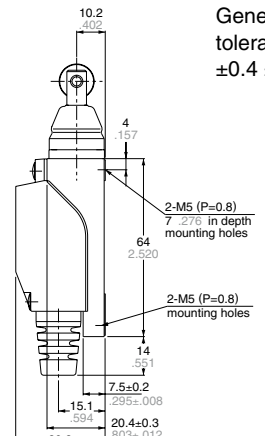
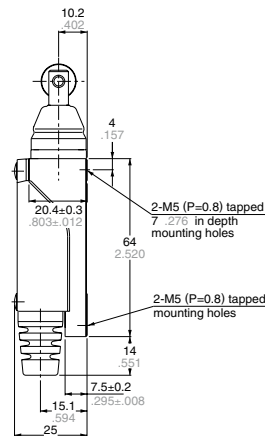
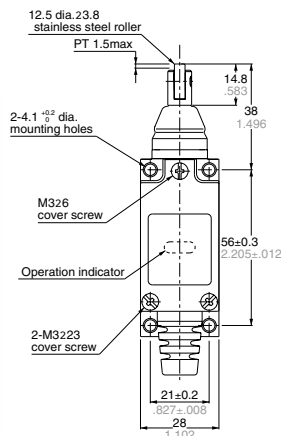

(Standard type)

(With Neon lamp)

General tolerance: $\pm 0.4 \pm .016$

Roller arm type

Standard type
AZ8104CEJ

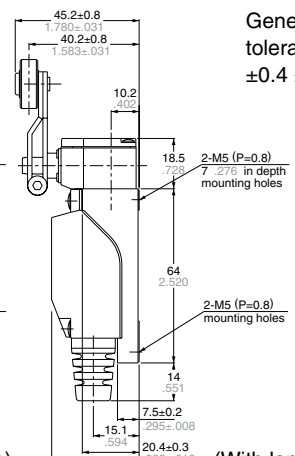
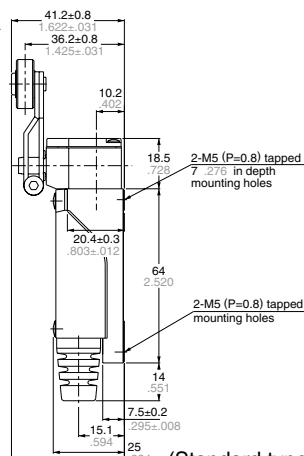
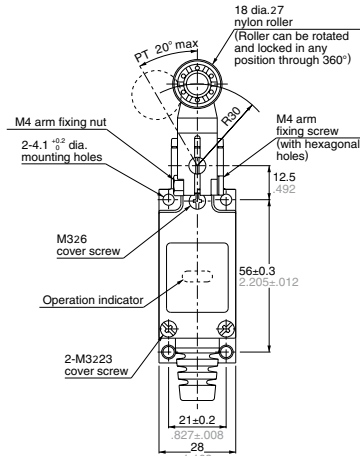

(Standard type)

(With lamp)

General tolerance: $\pm 0.4 \pm .016$

VL (AZ8)

Adjustable rod type

Standard type

AZ8107CEJ

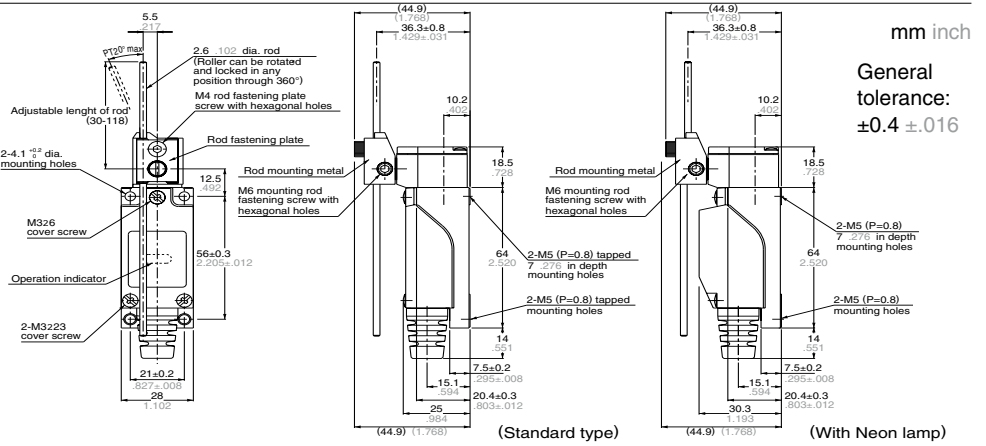

mm inch

General tolerance: ±0.4 ±.016

Adjustable roller arm type

Standard type

AZ8108CEJ

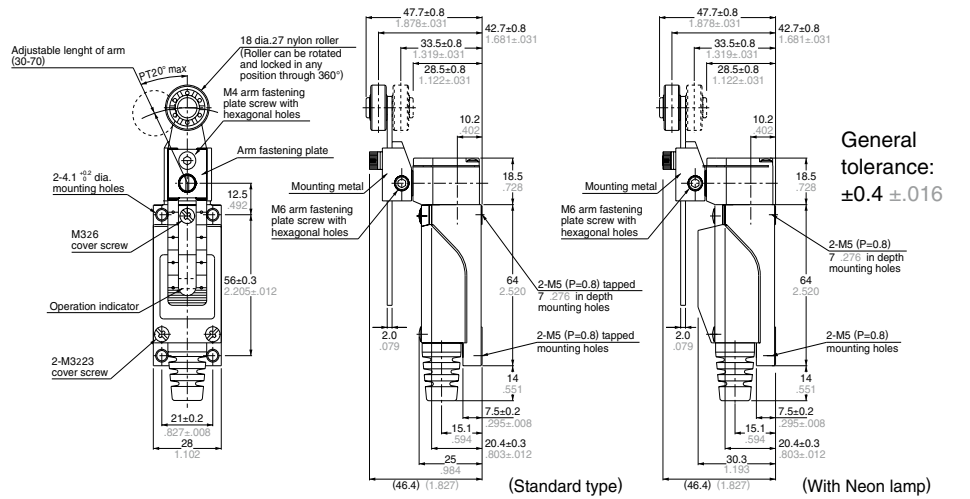

General tolerance: ±0.4 ±.016

(Length of arm can be adjustable within 30 to 70mm 1.181 to 2.756inch by 1mm .039inch pitch)

Flexible rod type

Standard type

AZ8166CEJ

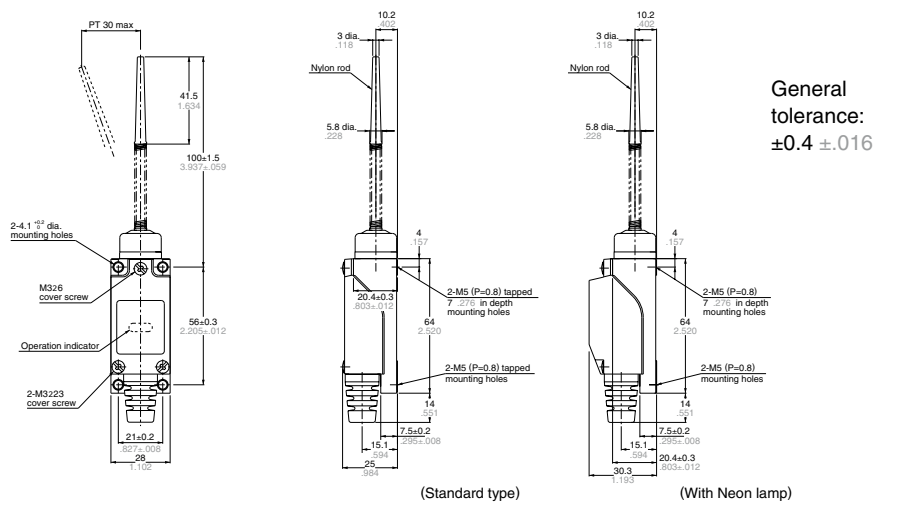

General tolerance: ±0.4 ±.016

(Should be used with less than 50mm 1.969inch of T.T.)

Spring wire type

Standard type

AZ8169CEJ

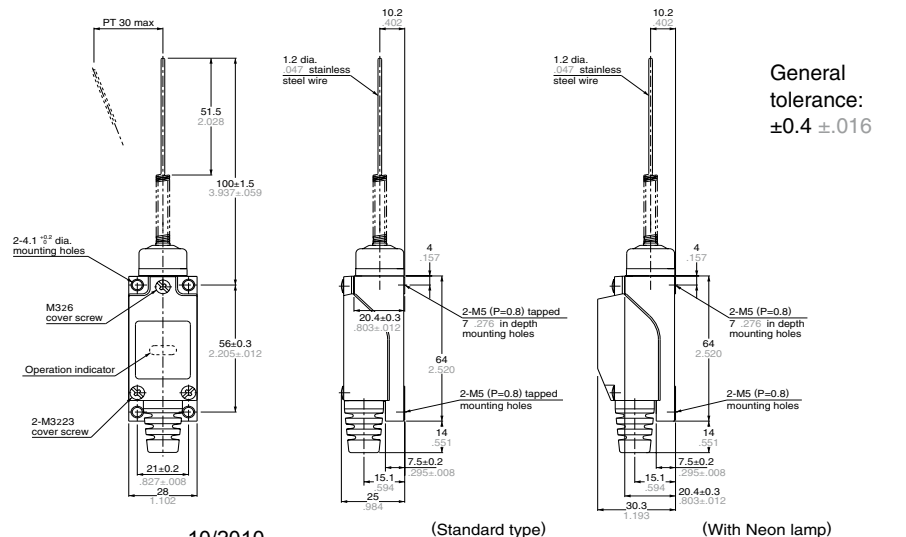

General tolerance: ±0.4 ±.016

(Should be used with less than 50mm 1.969inch of T.T.)

OPTION

VL Conduit Adaptor



AZ8801

Applicable wire

| Electric wire name | Finished outside diameter |
|---------------------------|---------------------------|
| Vinyl cabtire cord (VCTF) | 8.7 to 11 dia. |
| Vinyl cabtire cable (VCT) | .343 to .433 dia. |



(A set of mounting hex. socket screws is supplied.)

mm inch

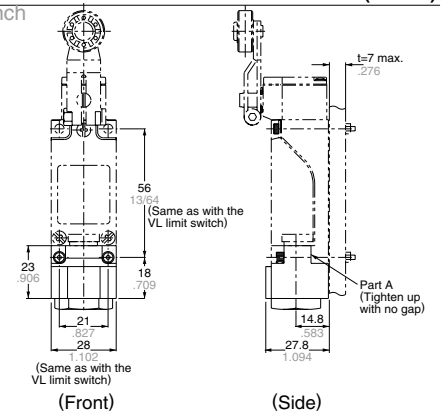

WIRING

mm inch

- Insulation distance more than 6.4mm .252inch for wiring and live parts
- Special assembly screws
- Grounding is available

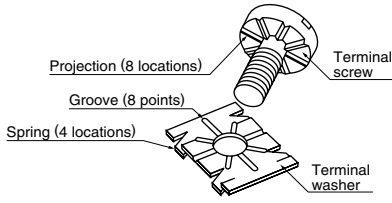

Applicable fasten terminal

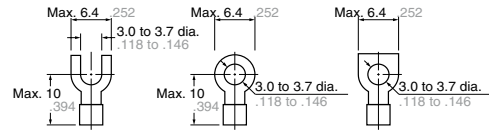

With insulated grip

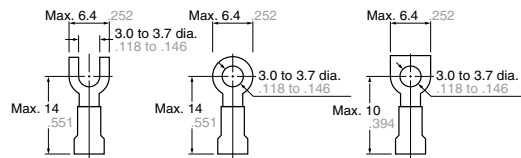

Cable treatment Ordinary terminal

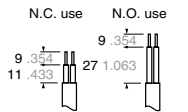

Fasten terminal

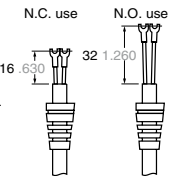

Applicable wire

| Wire name | Applicable wire | | |
|------------------------------------------|-----------------|------------------------------------------|---------------------------------|
| | Wire-strand | Conductor | Finished outside diameter |
| Vinyl cabtire cord (VCTF) | 2-wire | 0.75mm ² •1.25mm ² | Round shape 6 dia. to 9 dia. |
| | 3-wire | 2.0mm ² | |
| | 4-wire | 0.75mm ² •1.25mm ² | |
| Vinyl cabtire cable (VCT) | 2-wire | 0.75mm ² | Flat shape Max. 9.4 |
| 600V vinyl insulation sealed cable (VVF) | 2-wire | 1.0 dia. to 1.2 dia. 1.6 dia. | |

Inner construction

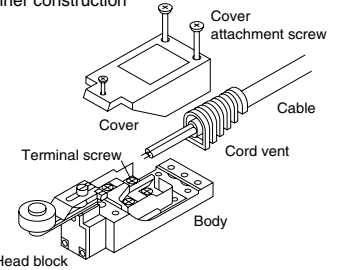

INDICATOR LIGHTING CIRCUIT

1. Spring type

1) When connecting load to N.O. side: When the switch is at free position, the indicator is lit, and when the switch operates, the indicator turns off. (Use the indicator holder in the same condition as when it was at the time of shipment.)

2) When connecting load to N.C. side: When connecting switch is at free position, the indicator turns off, and when the switch operates, the indicator is lit. (Use the lamp holder, changing it direction by 180°.)

3) When connecting loads to both N.O. and N.C. sides: Same as in 1). (Use the lamp holder in the same condition as when it was at the time of shipment. In this case, it is impossible to use it, changing its direction by 180°.)

(With neon lamp)

(With LED)

(With neon lamp)

(With LED)

(With neon lamp)

(With LED)

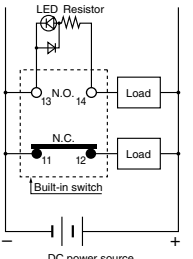
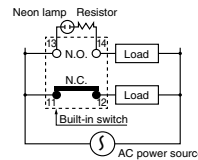
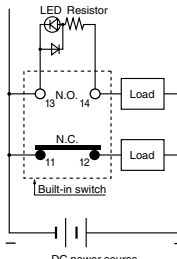
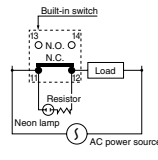
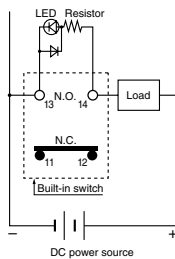
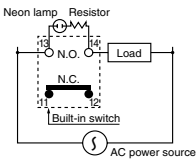

2. Lead wire type (only for types with LED)

1) When giving indication on N.O. side and N.C. side, operation is same as that in the case of the spring type. However, when load is connected to both N.O. side and N.C. side, indication can be given on both N.C. side and N.O. side.

2) When the indication circuit is connected with load in parallel: Load performs the same operation as the indication circuit does. (When load operates, the lamp is lit, and when load is turned off, the lamp goes out.)

- More loads than for one circuit cannot be controlled.
- There is no leakage current.

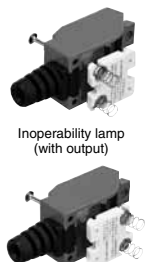
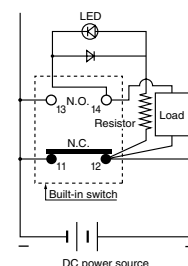

MOUNTING DIMENSIONS

Surface mounting

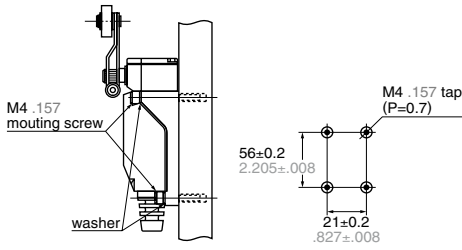

Depth of screw holes > 15mm .591inch

Through hole mounting

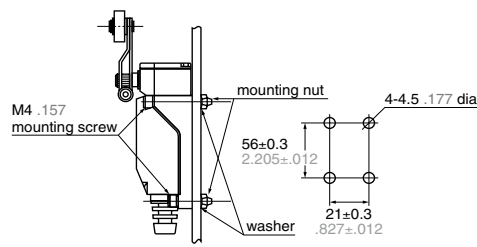

Thickness of panel < 5mm .197inch

Rear mounting

mm inch

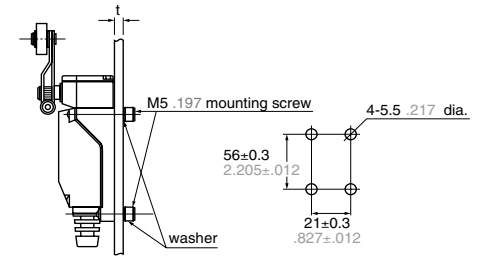

Length of bolt < panel thickness t+7mm .276inch

HEAD DIRECTION CHANGE

(Roller arm, adjustable roller arm, adjustable rod types)

Actuator heads may be moved in 90° increments to any of four directions, by removing one screw.

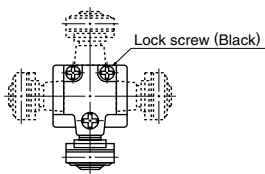

CAUTIONS

1. When overtravel is too large, life is shortened due to possible damage to the mechanism. Please use in the following appropriate range.

| Types | Overtravel |
|------------------------------------|------------------------------------------|
| Plunger (AZ8111, 8112, 8122) | 1.5 to 2.0mm .059 to .079inch |
| Roller Arm (AZ8104, 8107, 8108) | 20 to 30° |
| Flexible Rod (AZ8166, 8169) | 15 to 20mm .591 to .787inch (at the top) |

2. Because these switches are not of immersion protected construction, their use in water or oil should be avoided. Also, locations where water or oil can normally impinge upon the switch or where there is an excessive accumulation of dust should be avoided.

3. The use of these switches under the following conditions should be avoided. If the following conditions should become necessary, we recommend consulting us first.

- Use where there will be direct contact with organic solvents, strong acids or alkalis, or direct exposure to their vapors.
- Use where inflammable or corrosive gases exist.

4. In order to maintain the reliability at a high level under practical conditions of use, the actual operating conditions should be checked for the benefit of the quality of the product.

5. Mounting

Three cover screws should be fasten uniformly. The rubber for opening cord should be corrected as normal condition after connecting the wire.

6. How to change the indicator holder.

1) As shown in the photograph, wrench a minus-driver in the gap between the cover and the part of the indicator holder indicated by the arrow in the direction of insertion, and raise the lamp a little.

2) After removing the indicator holder, insert it in the reverse direction, and push it in until a snap is heard.

3) After changing the direction of the indicator holder, put the cover on it in such a way that the spring touches the top of the terminal screw.

(Unless the spring rests completely on the terminal screw, distortion of the spring, failure in lighting of the lamp or short circuit may result.)

7. Matters to be attended to in using spring type VL Limit Switch with indicator.

1) When loads are connected to both N.O. and N.C. only the indicator at non-operation time can be used.

2) Take special care not to damage or deform the contact spring during change of indicator holder direction or during connection work.

3) In the case of VL Limit Switch with Neon lamp, if the indicator is connected in series in a 100V circuit, the indicator ceases to be lighted.

However, for a 200V circuit, up to 2 lamps can be connected in series.

8. Matters to be attended to in using lead wire type VL with lamp.

1) When loads are connected to both N.O. and N.C. indication can be given on both N.O. and N.C. sides, but it is impossible to connect the indication circuit to the load in series.

