

### FEATURES

- 1. Economical prices achieved**
- 2. Useful for wide range of applications**

Gold-plated contact types are capable of switching under low level (1mA: reference value) to powerful high level (7A: 2-pole) loads.

- 3. Wide range of types available**

The lineup includes 2-pole and 4-pole products, relays with operating indicator lights, and push-button types. You will also find relays that absorb surge when the coil goes to the off state with diodes (for DC type) or CR circuits (for AC type). Moreover, the availability of a broad range of coil voltages meets a wide range of needs.

- 4. Coil cutoff detection**

The LED that is fitted to AC coils goes off when the coil is inoperative and so provides a cutoff detection function.

- 5. Finger protection**

Terminal sockets with finger protection, designed to prevent fingers from touching the terminals, are also available.

- 6. Sockets and terminal sockets are available.**

### TYPICAL APPLICATIONS

- Control panels
- Power supply units
- Molding machines
- Machine tools
- Welding equipment
- Agricultural equipment
- Office equipment
- Vending machines
- Communications equipment
- Amusement machines

### ORDERING INFORMATION

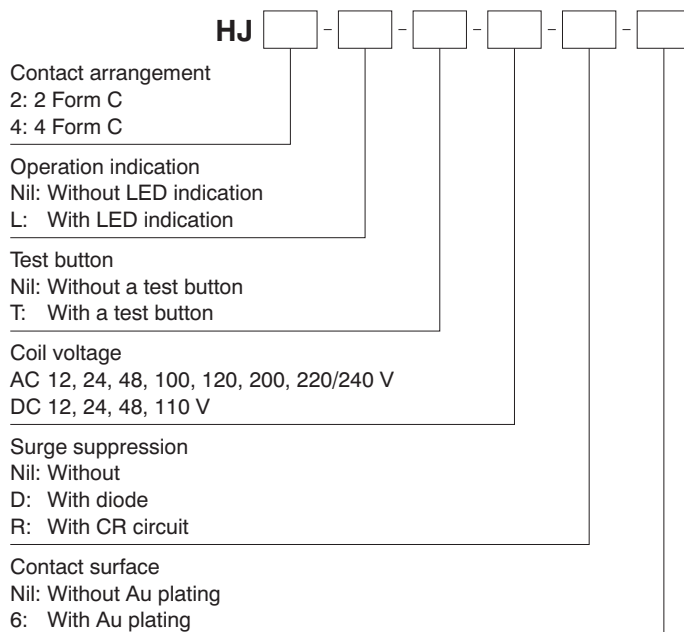

Note: Certified by UL/C-UL and TÜV.

## TYPES

[Au plating type]

## 1. Plug-in type

Coil voltage	2 Form C	4 Form C
	Part No.	Part No.
12V DC	HJ2-DC 12V-6	HJ4-DC 12V-6
24V DC	HJ2-DC 24V-6	HJ4-DC 24V-6
48V DC	HJ2-DC 48V-6	HJ4-DC 48V-6
100/110V DC	HJ2-DC110V-6	HJ4-DC110V-6
12V AC	HJ2-AC 12V-6	HJ4-AC 12V-6
24V AC	HJ2-AC 24V-6	HJ4-AC 24V-6
48V AC	HJ2-AC 48V-6	HJ4-AC 48V-6
100/110V AC	HJ2-AC100V-6	HJ4-AC100V-6
110/120V AC	HJ2-AC120V-6	HJ4-AC120V-6
200/220V AC	HJ2-AC200V-6	HJ4-AC200V-6
220/240V AC	HJ2-AC220/240V-6	HJ4-AC220/240V-6

Note: Packing quantity: 20pcs. (Carton), 200pcs. (Case)

## 2. Plug-in type (with LED indication)

Coil voltage	2 Form C	4 Form C
	Part No.	Part No.
12V DC	HJ2-L-DC 12V-6	HJ4-L-DC 12V-6
24V DC	HJ2-L-DC 24V-6	HJ4-L-DC 24V-6
48V DC	HJ2-L-DC 48V-6	HJ4-L-DC 48V-6
100/110V DC	HJ2-L-DC110V-6	HJ4-L-DC110V-6
12V AC	HJ2-L-AC 12V-6	HJ4-L-AC 12V-6
24V AC	HJ2-L-AC 24V-6	HJ4-L-AC 24V-6
48V AC	HJ2-L-AC 48V-6	HJ4-L-AC 48V-6
100/110V AC	HJ2-L-AC100V-6	HJ4-L-AC100V-6
110/120V AC	HJ2-L-AC120V-6	HJ4-L-AC120V-6
200/220V AC	HJ2-L-AC200V-6	HJ4-L-AC200V-6
220/240V AC	HJ2-L-AC220/240V-6	HJ4-L-AC220/240V-6

Note: Packing quantity: 20pcs. (Carton), 200pcs. (Case)

## 3. Plug-in type (with diode)

Coil voltage	2 Form C	4 Form C
	Part No.	Part No.
12V DC	HJ2-DC 12V-D-6	HJ4-DC 12V-D-6
24V DC	HJ2-DC 24V-D-6	HJ4-DC 24V-D-6
48V DC	HJ2-DC 48V-D-6	HJ4-DC 48V-D-6
100/110V DC	HJ2-DC110V-D-6	HJ4-DC110V-D-6

Note: Packing quantity: 20pcs. (Carton), 200pcs. (Case)

## 4. Plug-in type (with diode and LED indication)

Coil voltage	2 Form C	4 Form C
	Part No.	Part No.
12V DC	HJ2-L-DC 12V-D-6	HJ4-L-DC 12V-D-6
24V DC	HJ2-L-DC 24V-D-6	HJ4-L-DC 24V-D-6
48V DC	HJ2-L-DC 48V-D-6	HJ4-L-DC 48V-D-6
100/110V DC	HJ2-L-DC110V-D-6	HJ4-L-DC110V-D-6

Note: Packing quantity: 20pcs. (Carton), 200pcs. (Case)

## 5. Plug-in type (with CR)

Coil voltage	2 Form C	4 Form C
	Part No.	Part No.
100/110V AC	HJ2-AC100V-R-6	HJ4-AC100V-R-6
110/120V AC	HJ2-AC120V-R-6	HJ4-AC120V-R-6
200/220V AC	HJ2-AC200V-R-6	HJ4-AC200V-R-6
220/240V AC	HJ2-AC220/240V-R-6	HJ4-AC220/240V-R-6

Note: Packing quantity: 20pcs. (Carton), 200pcs. (Case)

## 6. Plug-in type (with CR and LED indication)

Coil voltage	2 Form C	4 Form C
	Part No.	Part No.
100/110V AC	HJ2-L-AC100V-R-6	HJ4-L-AC100V-R-6
110/120V AC	HJ2-L-AC120V-R-6	HJ4-L-AC120V-R-6
200/220V AC	HJ2-L-AC200V-R-6	HJ4-L-AC200V-R-6
220/240V AC	HJ2-L-AC220/240V-R-6	HJ4-L-AC220/240V-R-6

Note: Packing quantity: 20pcs. (Carton), 200pcs. (Case)

[Without Au plating type]

## 1. Plug-in type

Coil voltage	2 Form C	4 Form C
	Part No.	Part No.
12V DC	HJ2-DC 12V	HJ4-DC 12V
24V DC	HJ2-DC 24V	HJ4-DC 24V
48V DC	HJ2-DC 48V	HJ4-DC 48V
100/110V DC	HJ2-DC110V	HJ4-DC110V
12V AC	HJ2-AC 12V	HJ4-AC 12V
24V AC	HJ2-AC 24V	HJ4-AC 24V
48V AC	HJ2-AC 48V	HJ4-AC 48V
100/110V AC	HJ2-AC100V	HJ4-AC100V
110/120V AC	HJ2-AC120V	HJ4-AC120V
200/220V AC	HJ2-AC200V	HJ4-AC200V
220/240V AC	HJ2-AC220/240V	HJ4-AC220/240V

Note: Packing quantity: 20pcs. (Carton), 200pcs. (Case)

## 2. Plug-in type (with LED indication)

Coil voltage	2 Form C	4 Form C
	Part No.	Part No.
12V DC	HJ2-L-DC 12V	HJ4-L-DC 12V
24V DC	HJ2-L-DC 24V	HJ4-L-DC 24V
48V DC	HJ2-L-DC 48V	HJ4-L-DC 48V
100/110V DC	HJ2-L-DC110V	HJ4-L-DC110V
12V AC	HJ2-L-AC 12V	HJ4-L-AC 12V
24V AC	HJ2-L-AC 24V	HJ4-L-AC 24V
48V AC	HJ2-L-AC 48V	HJ4-L-AC 48V
100/110V AC	HJ2-L-AC100V	HJ4-L-AC100V
110/120V AC	HJ2-L-AC120V	HJ4-L-AC120V
200/220V AC	HJ2-L-AC200V	HJ4-L-AC200V
220/240V AC	HJ2-L-AC220/240V	HJ4-L-AC220/240V

Note: Packing quantity: 20pcs. (Carton), 200pcs. (Case)

## 3. Plug-in type (with a test button)

Coil voltage	2 Form C	4 Form C
	Part No.	Part No.
12V DC	HJ2-T-DC 12V	HJ4-T-DC 12V
24V DC	HJ2-T-DC 24V	HJ4-T-DC 24V
100/110V AC	HJ2-T-AC100V	HJ4-T-AC100V
200/220V AC	HJ2-T-AC200V	HJ4-T-AC200V

Note: Packing quantity: 20pcs. (Carton), 200pcs. (Case)

## 4. Plug-in type (with LED indication and a test button)

Coil voltage	2 Form C	4 Form C
	Part No.	Part No.
12V DC	HJ2-L-T-DC 12V	HJ4-L-T-DC 12V
24V DC	HJ2-L-T-DC 24V	HJ4-L-T-DC 24V
100/110V AC	HJ2-L-T-AC100V	HJ4-L-T-AC100V
200/220V AC	HJ2-L-T-AC200V	HJ4-L-T-AC200V

Note: Packing quantity: 20pcs. (Carton), 200pcs. (Case)

**5. Plug-in type (with diode)**

Coil voltage	2 Form C	4 Form C
	Part No.	Part No.
12V DC	HJ2-DC 12V-D	HJ4-DC 12V-D
24V DC	HJ2-DC 24V-D	HJ4-DC 24V-D
48V DC	HJ2-DC 48V-D	HJ4-DC 48V-D
100/110V DC	HJ2-DC110V-D	HJ4-DC110V-D

Note: Packing quantity: 20pcs. (Carton), 200pcs. (Case)

**6. Plug-in type (with diode and LED indication)**

Coil voltage	2 Form C	4 Form C
	Part No.	Part No.
12V DC	HJ2-L-DC 12V-D	HJ4-L-DC 12V-D
24V DC	HJ2-L-DC 24V-D	HJ4-L-DC 24V-D
48V DC	HJ2-L-DC 48V-D	HJ4-L-DC 48V-D
100/110V DC	HJ2-L-DC110V-D	HJ4-L-DC110V-D

Note: Packing quantity: 20pcs. (Carton), 200pcs. (Case)

**7. Plug-in type (with CR)**

Coil voltage	2 Form C	4 Form C
	Part No.	Part No.
100/110V AC	HJ2-AC100V-R	HJ4-AC100V-R
110/120V AC	HJ2-AC120V-R	HJ4-AC120V-R
200/220V AC	HJ2-AC200V-R	HJ4-AC200V-R
220/240V AC	HJ2-AC220/240V-R	HJ4-AC220/240V-R

Note: Packing quantity: 20pcs. (Carton), 200pcs. (Case)

**8. Plug-in type (with CR and LED indication)**

Coil voltage	2 Form C	4 Form C
	Part No.	Part No.
100/110V AC	HJ2-L-AC100V-R	HJ4-L-AC100V-R
110/120V AC	HJ2-L-AC120V-R	HJ4-L-AC120V-R
200/220V AC	HJ2-L-AC200V-R	HJ4-L-AC200V-R
220/240V AC	HJ2-L-AC220/240V-R	HJ4-L-AC220/240V-R

Note: Packing quantity: 20pcs. (Carton), 200pcs. (Case)

**\* For sockets and terminal sockets, see page 8.****RATING****1. Coil data****1) AC coils (50/60Hz)**

Coil voltage	Pick-up voltage (at 20°C 68°F)	Drop-out voltage (at 20°C 68°F)	Nominal coil current [±20%]		Nominal operating power		Max. allowable voltage (at 70°C 158°F)
			50Hz	60Hz	50Hz	60Hz	
12V AC	80%V or less of nominal voltage (Initial)	30%V or more of nominal voltage (Initial)	102.9mA	85.4mA	Approx. 1.2 to 1.5 V A	Approx. 1.0 to 1.3 V A	110%V of nominal voltage
24V AC			54.5mA	45.6mA			
48V AC			30.7mA	25.9mA			
100/110V AC			11.8mA/13.9mA	10.0mA/11.6mA			
110/120V AC			10.9mA/12.5mA	9.1mA/10.3mA			
200/220V AC			6.8mA/8.1mA	5.7mA/6.7mA			
220/240V AC			6.8mA/7.8mA	5.6mA/6.4mA			

**2) DC coils**

Coil voltage	Pick-up voltage (at 20°C 68°F)	Drop-out voltage (at 20°C 68°F)	Nominal coil current	Coil resistance (at 20°C 68°F)	Nominal operating power	Max. allowable voltage (at 70°C 158°F)
12V DC	80%V or less of nominal voltage (Initial)	10%V or more of nominal voltage (Initial)	75mA [±10%]	160Ω	0.9W	110%V of nominal voltage
24V DC			37mA [±10%]	650Ω	0.9W	
48V DC			18mA [±15%]	2,600Ω	0.9W	
100/110V DC			9.1mA/10mA [±15%]	11,000Ω	1.1W	

## 2. Specifications

Characteristics	Item	Specifications		
Contact	Arrangement	2 Form C	4 Form C	
	Initial contact resistance, max	Max. 50 mΩ (By voltage drop 6 V DC 1A)		
	Contact material	Au plating type: Au plating Ag Without Au plating type: Ag		
Rating	Nominal switching capacity (resistive load)	7 A 250V AC	5 A 250V AC	
	Max. switching power (resistive load)	1,750 VA	1,250 VA	
	Max. switching voltage	250V AC, 125V DC		
	Max. switching current	7 A	5 A	
	Nominal operating power	0.9W 1.2 VA		
	Min. switching capacity (Reference value)*1	Au plating type	1mA 1V DC	
		Without Au plating type	1mA 5V DC	
Electrical characteristics	Insulation resistance (Initial)		Min. 100MΩ (at 500V DC) Measurement at same location as "Initial breakdown voltage" section.	
	Breakdown voltage (Initial)	Between open contacts	1,000 Vrms for 1min. (Detection current: 10mA.)	
		Between contact sets	2,000 Vrms for 1min. (Detection current: 10mA.)	
		Between contact and coil	2,000 Vrms for 1min. (Detection current: 10mA.)	
	Temperature rise (at 70°C 158°F)		Max. 60°C (By resistive method, nominal voltage)	
	Operate time*2		Max. 20ms (Nominal voltage applied to the coil, excluding contact bounce time.)	
Release time*2		Max. 20ms (Nominal voltage applied to the coil, excluding contact bounce time.) (without diode)		
Mechanical characteristics	Shock resistance	Functional	Min. 100 m/s <sup>2</sup> (Half-wave pulse of sine wave: 11 ms; detection time: 10μs.)	
		Destructive	Min. 1,000 m/s <sup>2</sup> (Half-wave pulse of sine wave: 6 ms.)	
	Vibration resistance	Functional	10 to 55 Hz at double amplitude of 1.0 mm (Detection time: 10μs.)	
		Destructive	10 to 55 Hz at double amplitude of 1.0 mm	
Expected life	Mechanical	Min. 2×10 <sup>7</sup> (at 180 cpm)		
	Electrical (resistive load) (at 20 cpm)	Min. 10 <sup>6</sup> (7A 250V AC) Min. 5×10 <sup>5</sup> (5A 250V AC)	Min. 10 <sup>5</sup> (5A 250V AC) Min. 2×10 <sup>5</sup> (3A 250V AC)	
Conditions	Conditions for operation, transport and storage*3 (Not freezing and condensing at low temperature)	Ambient temperature: -40°C to +70°C -40°F to +158°F Humidity: 5 to 85% R.H. (Not freezing and condensing at low temperature)		
	Max. Operating speed	20 times/min. (at nominal switching capacity)		
Unit weight		Approx. 34g 1.20 oz		

Notes:  
In accordance with the Electrical Appliance and Material Safety Law, you cannot exceed a voltage of 150V AC when using the 4 Form C type.  
For more information, please inquire.

When using low level loads, contact instability may result depending on conditions of use (switching frequency and ambient conditions, etc.); therefore, please use the Au plating type.

\*1 This value can change due to the switching frequency, environmental conditions and desired reliability level, therefore it is recommended to check this with the actual load.

\*2 For the AC coil types, the operate/release time will differ depending on the phase.

\*3. The upper limit of the ambient temperature is the maximum temperature that can satisfy the coil temperature rise value. Refer to Usage, transport and storage conditions in NOTES on page 8.

\*4. When using the socket and terminal socket, be sure to verify the max. continuous current.

## REFERENCE DATA

1-(1). Max. switching capacity (2 Form C type)

1-(2). Max. switching capacity (4 Form C type)

2-(1). Life curve (2 Form C)

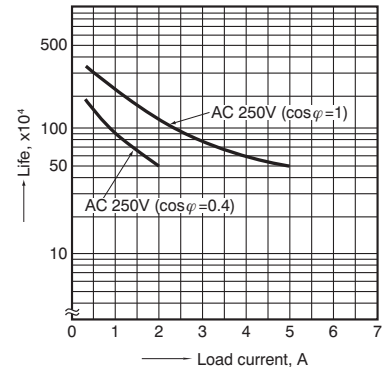
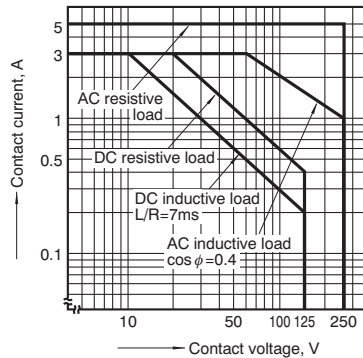
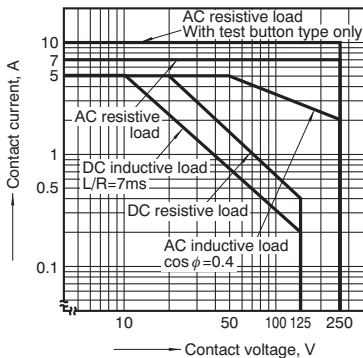

2-(2). Life curve (4 Form C)

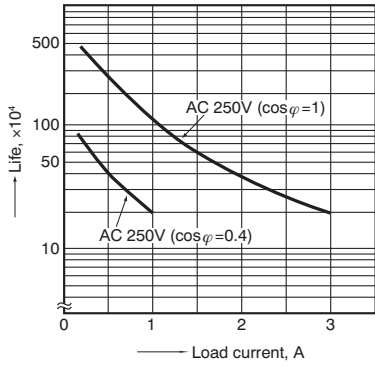

3-(1). Coil temperature rise (2 Form C/AC type)

Measured portion: Inside the coil  
Ambient temperature: 70°C 158°F

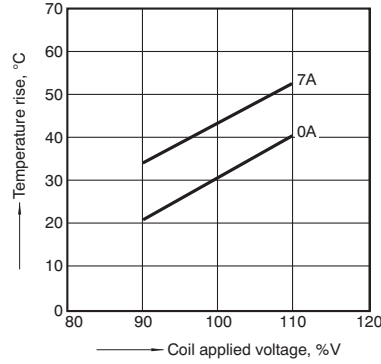

3-(2). Coil temperature rise (2 Form C/DC type)

Measured portion: Inside the coil  
Ambient temperature: 70°C 158°F

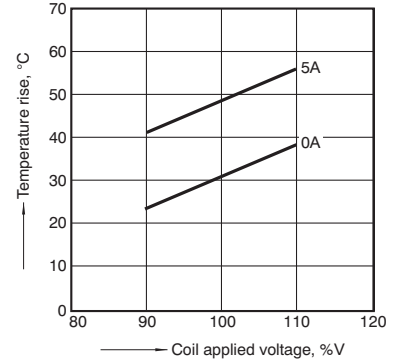

3-(3). Coil temperature rise (4 Form C/AC type)

Measured portion: Inside the coil  
Ambient temperature: 70°C 158°F

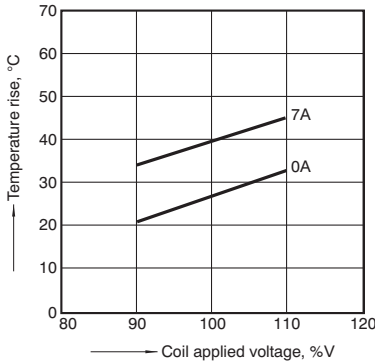

3-(4). Coil temperature rise (4 Form C/DC type)

Measured portion: Inside the coil  
Ambient temperature: 70°C 158°F

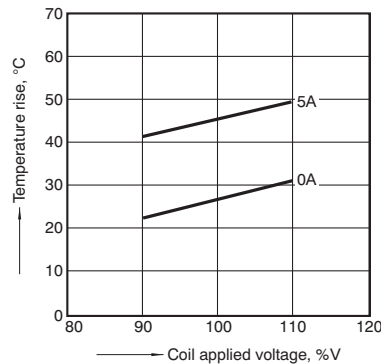

4-(1). AC coil surge voltage waveform (With CR circuit)

Tested sample: HJ4-AC200V-R

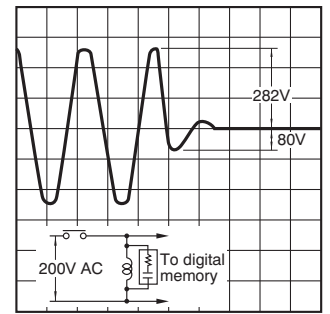

4-(2). AC coil surge voltage waveform (Without CR circuit)

Tested sample: HJ4-AC200V

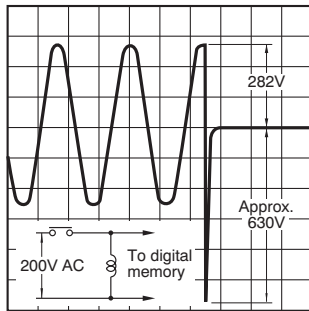

5-(1). DC coil surge voltage waveform (Without diode)

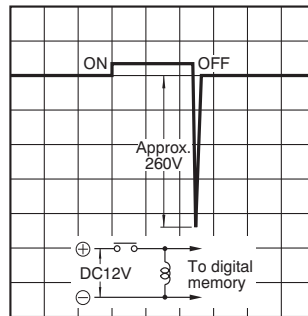

5-(2). DC coil surge voltage waveform (With diode)

Diode characteristics:  
Reverse breakdown voltage: 1,000 V  
Forward current: 1 A

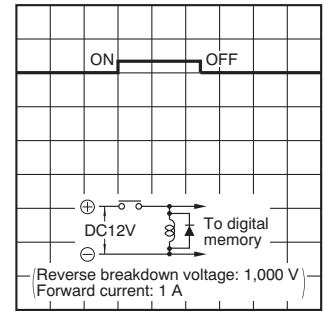

**DIMENSIONS**(mm inch)

Download [CAD Data](#) from our Web site.

**1. Plug-in type (2 Form C)  
(including diode/CR)**

[CAD Data](#)

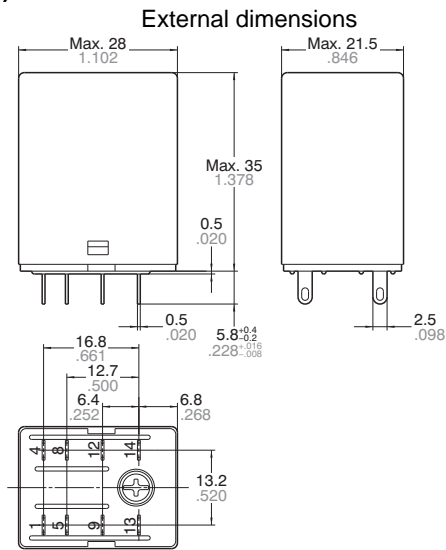

**Dimension:**  
 Less than 1mm .039 inch;  
 Min. 1mm .039 less than 3mm .118 inch;  
 Min. 3mm .118 inch;

**Schematic (Bottom view)**

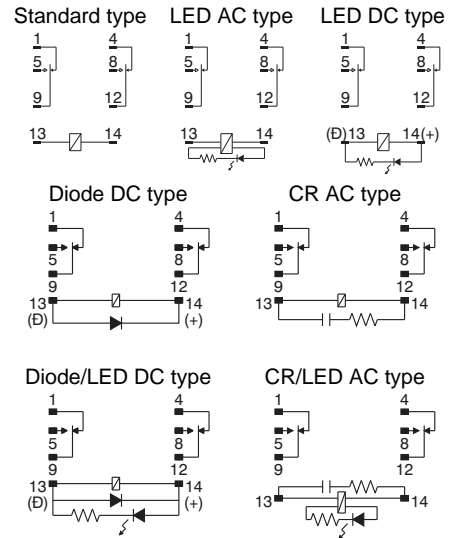

**Tolerance**  
 $\pm 0.1 \pm .004$   
 $\pm 0.2 \pm .008$   
 $\pm 0.3 \pm .012$

**2. Plug-in type (4 Form C)  
(including diode/CR)**

[CAD Data](#)

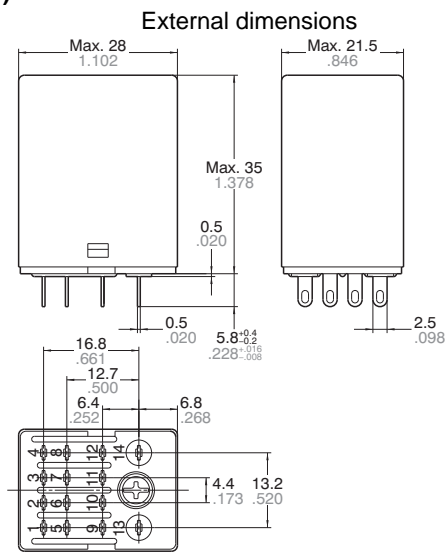

**Dimension:**  
 Less than 1mm .039 inch;  
 Min. 1mm .039 less than 3mm .118 inch;  
 Min. 3mm .118 inch;

**Schematic (Bottom view)**

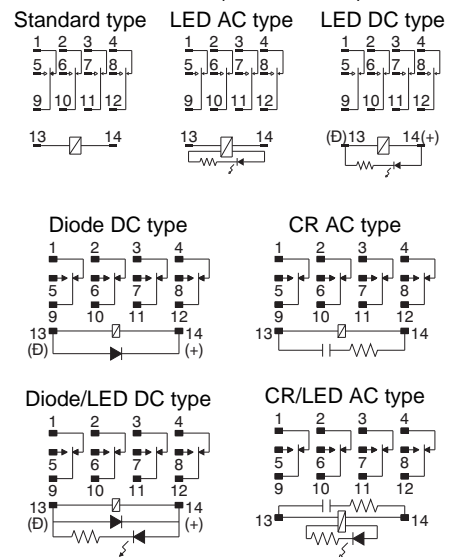

**Tolerance**  
 $\pm 0.1 \pm .004$   
 $\pm 0.2 \pm .008$   
 $\pm 0.3 \pm .012$

**3. Plug-in type with a test button (2 Form C)**

[CAD Data](#)

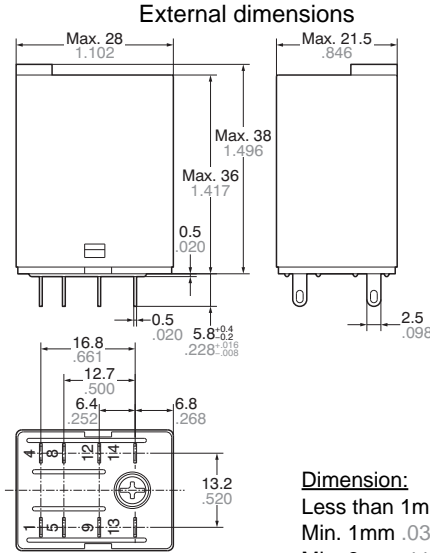

**Dimension:**  
 Less than 1mm .039 inch:  
 Min. 1mm .039 less than 3mm .118 inch:  
 Min. 3mm .118 inch:

**Tolerance**  
 ±0.1 ±.004  
 ±0.2 ±.008  
 ±0.3 ±.012

**Schematic (Bottom view)**

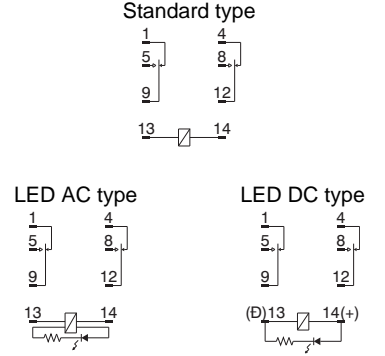

**4. Plug-in type with a test button (4 Form C)**

[CAD Data](#)

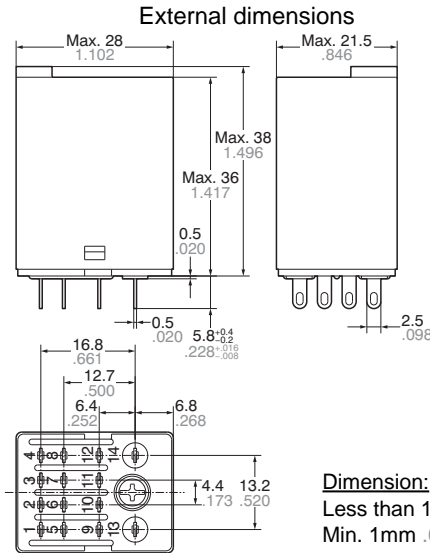

**Dimension:**  
 Less than 1mm .039 inch:  
 Min. 1mm .039 less than 3mm .118 inch:  
 Min. 3mm .118 inch:

**Tolerance**  
 ±0.1 ±.004  
 ±0.2 ±.008  
 ±0.3 ±.012

**Schematic (Bottom view)**

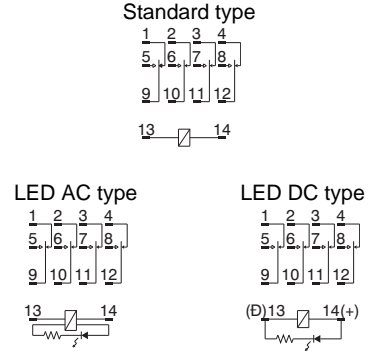

**SAFETY STANDARDS**

	File No.	Certification authority: UL/C-UL	File No.	Certification authority: TÜV
2 Form C	E43149*	7A 250V AC, 7A 30V DC	R2024382 (Standard) R2-50006950, R50049126 (Except standard)	7A 250V AC (cosφ=1.0), 7A 30V DC (0ms) Test button type: 10A 250V AC (cosφ=1.0), 10A 30V DC (0ms)
4 Form C	E43149*	5A 250V AC, 5A 30V DC	R2024382 (Standard) R50049126 (Except standard)	5A 250V AC (cosφ=1.0), 5A 30V DC (0ms)

\* CSA standard: Certified by C-UL

## NOTES

### 1. Coil applied voltage

Please refer to "RATING" about coil input power supply.

### 2. LED display

Operation is displayed by the light emitted from the LED. The LED may remain briefly lit if voltage remains after the relay opens.

### 3. Switching lifetime

The switching lifetime is defined under the standard test condition specified in the JIS\* C 5442 standard (temperature 15 to 35°C 59 to 95°F, humidity 25 to 75%). Check this with the real device as it is affected by coil driving circuit, load type, activation frequency, activation phase, ambient conditions and other factors.

Also, be especially careful of loads such as those listed below.

1) When used for AC load-operating and the operating phase is synchronous.

Rocking and fusing can easily occur due to contact shifting.

2) High-frequency load-operating

When high-frequency opening and closing of the relay is performed with a load that causes arcs at the contacts, nitrogen and oxygen in the air is fused by the arc energy and  $\text{HNO}_3$  is formed. This can corrode metal materials.

Three countermeasures for these are listed here.

(1) Incorporate an arc-extinguishing circuit.

(2) Lower the operating frequency

(3) Lower the ambient humidity

### 4. Usage, transport and storage conditions

1) Temperature, humidity and pressure during usage, storage and transport

(1) Temperature:

−40 to +70°C −40 to +158°F

(2) Humidity: 5 to 85% RH

(Avoid freezing and condensation.)

The humidity range varies with the temperature. Use within the range indicated in the graph below.

Temperature and humidity range for usage, transport, and storage

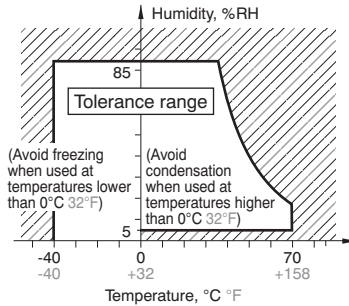

(3) Atmospheric pressure: 86 to 106 kPa

2) Condensation

Condensation forms when there is a sudden change in temperature under high temperature and high humidity conditions. Condensation will cause deterioration of the relay insulation.

3) Freezing

Condensation or other moisture may freeze on the relay when the temperatures is lower than 0°C 32°F. This causes problems such as sticking of movable parts or operational time lags.

4) Low temperature, low humidity environments

The plastic becomes brittle if the relay is exposed to a low temperature, low humidity environment for long periods of time.

### 5. Operation method for test button

1) Push and release 1 gently to confirm relay switching.

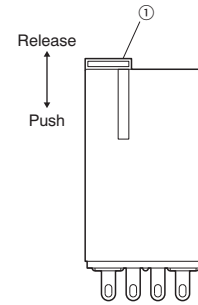

2) To lock to one side turn 90° counter-clockwise while pushing lock and turn 90° clockwise to release.

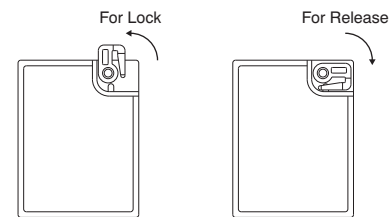

3) Do not use the test button for anything other than testing, such as when checking the circuit.

### 6. Diode characteristics

1) Reverse breakdown voltage: 1,000 V

2) Forward current: 1 A

### 7. Diode and CR built-in type

Since the diode and CR inside the relay coil are designed to absorb the counter emf, the element may be damaged if a large surge, etc., is applied to the diode and CR. If there is the possibility of a large surge voltage from the outside, please implement measures to absorb it.

**For Cautions for Use, see [Relay Technical Information](#).**



**TYPES**

Type	No. of poles	Product name	Part No.
Plug-in socket	2-pole	HC2-socket (for HJ relay)	HC2-SS-K-H105
	2/4-pole (common)	HC4-socket (for HJ relay)	HC4-SS-K-H105
PC board socket	2-pole	HC2-PC board socket (for HJ relay)	HC2-PS-K-H105
	2/4-pole (common)	HC4-PC board socket (for HJ relay)	HC4-PS-K-H105
DIN rail terminal socket	2-pole	HJ2 terminal socket	HJ2-SFD
		HJ2 terminal socket (Finger protect type)	HJ2-SFD-S
	2/4-pole (common)	HJ4 terminal socket	HJ4-SFD
		HJ4 terminal socket (Finger protect type)	HJ4-SFD-S

Standard packing: Carton: 10 pcs.; Case: 100 pcs.

Notes: 1. Use the hold-down clip that is shipped with the terminal socket or socket.

2. DIN rail terminal sockets conform to UL/C-UL and TÜV, as standard. Sockets conform to UL and CSA, as standard.

3. In order to prevent breakage and disfiguring, the screw tightening torque for the terminal socket should be within the range of 0.49 to 0.69 N·m (5 to 7 kgf·cm).

4. When attaching directly to a chassis, please use an M4 × 10 metric coarse screw thread, a spring washer, and a hexagonal nut.

5. For S1DX/S1DXM timer, use the leaf holding clip (Part No. ADX18012).

**RATING**

**Specifications (Sockets and terminal sockets)**

Item	Performance							
	For HC2/HJ Plug in terminal socket	For HC2/HJ PC board socket	HJ2 terminal socket	HJ2 terminal socket (Finger protect type)	For HC4/HJ Plug in terminal socket	For HC4/HJ PC board socket	HJ4 terminal socket	HJ4 terminal socket (Finger protect type)
Contact arrangement	2 Form C (2-pole)				4 Form C (2/4-pole common)			
Max. continuous current (Ambient temperature: -40/-50 to +70°C -40/-58 to +158°F)	7A	7A	7A	7A	5A	5A	5A	5A
Breakdown voltage (Initial)	Between open contacts	2,000 Vrms for 1 min. (Detection current: 10mA)						
	Between contact sets							
	Between contact and coil							
Initial insulation resistance	100 MΩ between each terminal (500V DC)							

Note: When using 2-pole of HJ relay (7A rating) on a 4 Form C socket and terminal socket that is 2/4-pole common, please use within a range that does not exceed the max. continuous current (5A).

**DIMENSIONS (mm inch)**

**1. Plug-in socket**

HC2 - Socket for HJ relay (HC2-SS-K-H105)

HC4 - Socket for HJ relay (HC4-SS-K-H105)

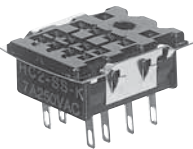

External dimensions

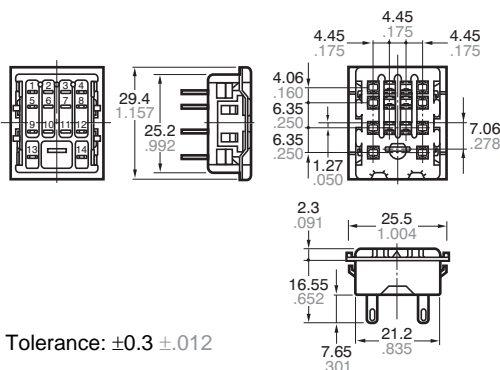

Tolerance:  $\pm 0.3 \pm 0.12$

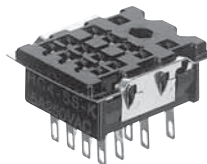

External dimensions

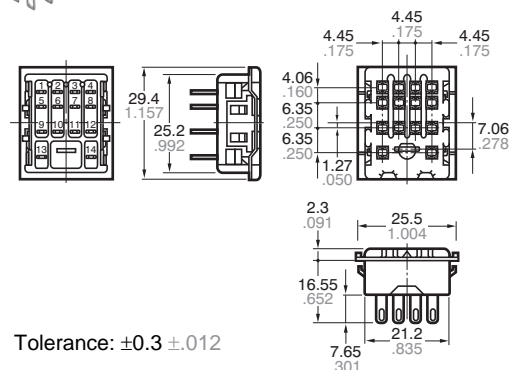

Tolerance:  $\pm 0.3 \pm 0.12$

## Mounting hole diagram

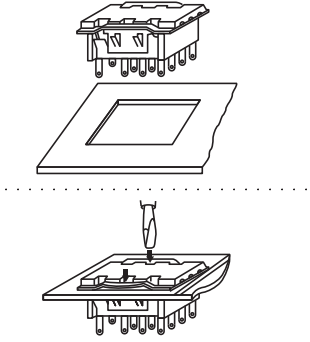

### Chassis cutout (Side-by-side installation)

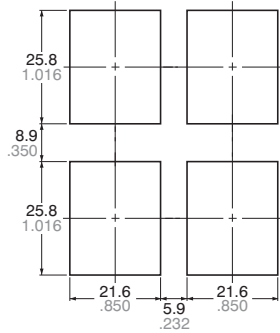

Tolerance:  $\pm 0.2 \pm 0.08$

- Notes: 1. Applicable chassis board thickness is 1.0 to 2.0 mm.  
 2. Installation is easy by inserting the socket from the top into the holes and by depressing the two down arrows on the retention fitting from the front.

### With a relay mounted (HC2-SS-K-H105)



Hold-down clip is packaged with the socket. (Same product as plug-in socket (Part No.: HC2-SS-K) for HC relay except that hold-down clip shape is different.)

## 2. PC board socket

HC2 - PC board socket for HJ relay (HC2-PS-K-H105)

HC4 - PC board socket for HJ relay (HC4-PS-K-H105)

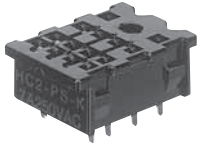

External dimensions

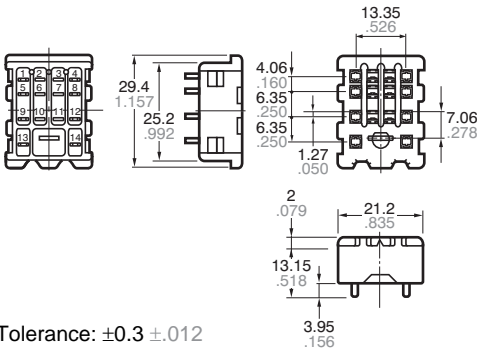

Tolerance:  $\pm 0.3 \pm 0.012$

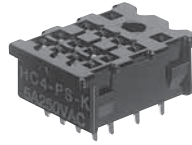

External dimensions

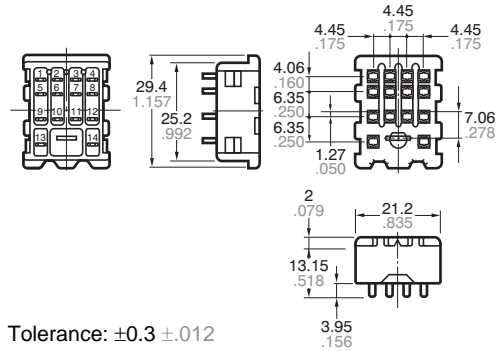

Tolerance:  $\pm 0.3 \pm 0.012$

## PC board pattern (BOTTOM VIEW)

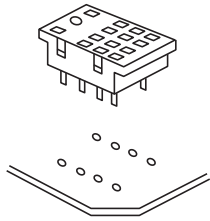

2 Form C

4 Form C

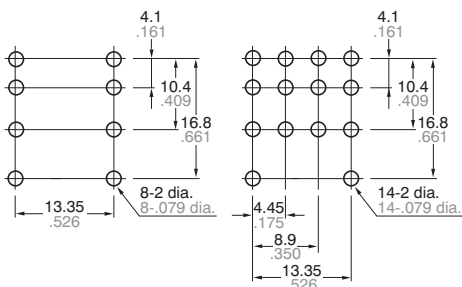

### Chassis cutout (Side-by-side installation)

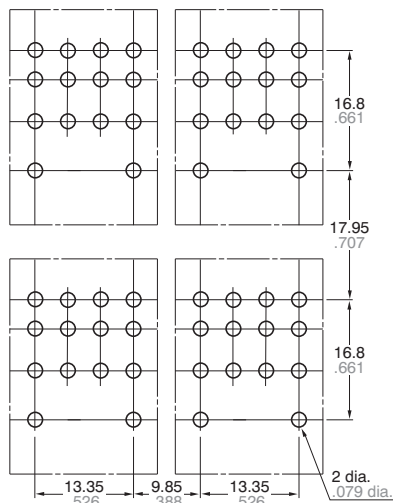

Tolerance:  $\pm 0.1 \pm 0.004$

### With a relay mounted (HC2-PS-K-H105)



Hold-down clip is packaged with the socket. (Same product as PC board socket (Part No.: HC2-PS-K) for HC relay except that hold-down clip shape is different.)

**3. Terminal socket**

HJ2 terminal socket (HJ2-SFD)

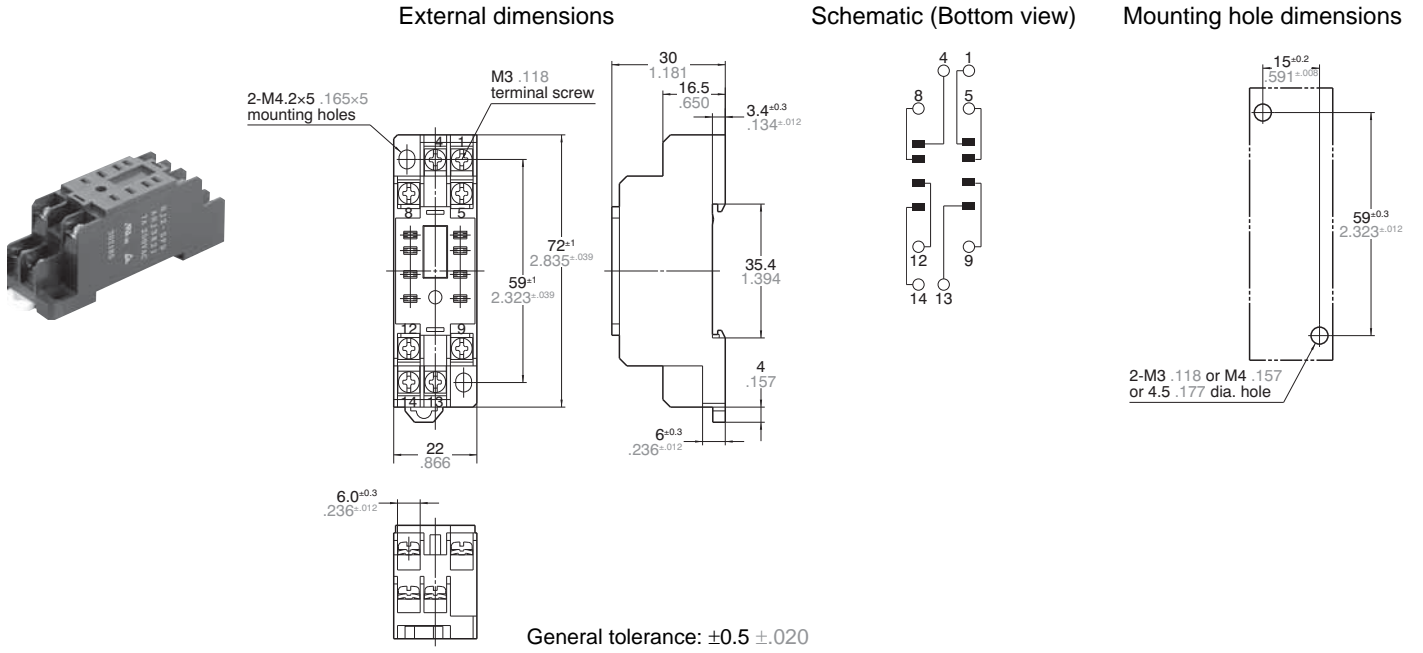

HJ2 terminal socket (Finger protect type) (HJ2-SFD-S)

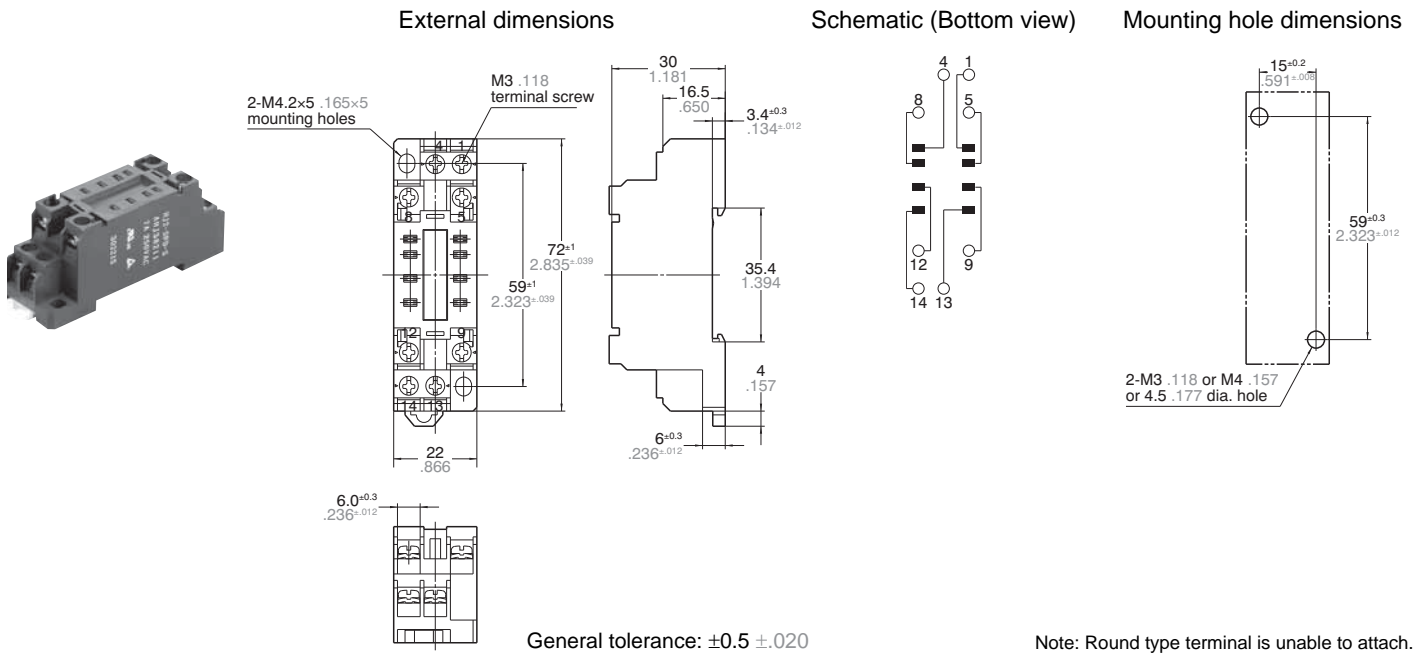

## HJ4 terminal socket (HJ4-SFD)

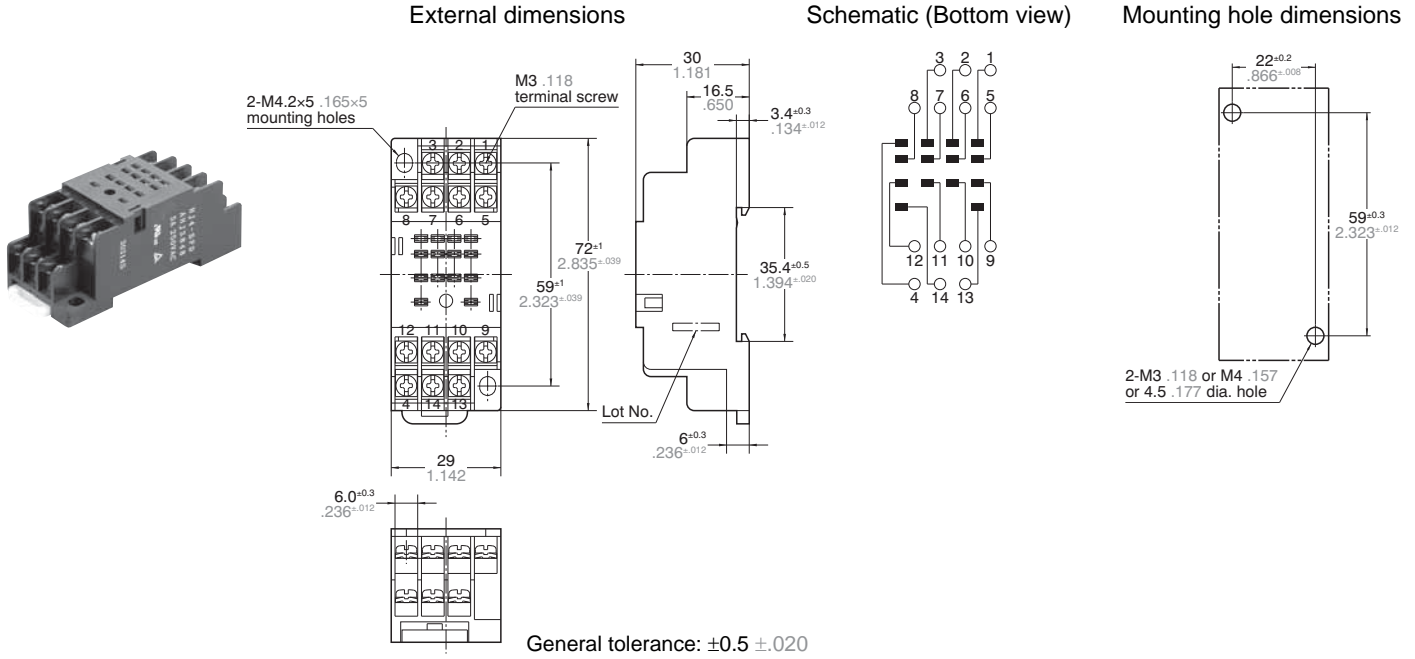

## HJ4 terminal socket (Finger protect type) (HJ4-SFD-S)

